

Configurations		
For safety	Steering speed limit	●
	Reverse handle with horn	●
	OPS	●
	Safety protecting function of multiway valve overload	●
	Reverse buzzer	●
	Upper buffering	●
	Central wide-angle rearview mirror	●
	Rearview mirrors on two sides	○
	Front protective net	○
	Seat with safety belt	○
	Dry powder fire extinguisher (0.5kg)	○
	Dry powder fire extinguisher (2kg)	○
	Reverse Chinese voice speaker	○
	Reversing parking sensor (4 probes)	○
Reversing image( 1 camera+ 4 probes)	○	
For driving comfort	Semi-enclosed seat	●
	USB (5V/1A)	●
	Steering with steering wheel start	●
	Mechanical operation valve	●
	Colorful instrument	●
	Full suspension seat	○
	Electromagnetic operated valve	○
	Fan	○
	Heater	○
	For cab/windshield	Panel mounted cab
Front windshield		○
Rear windshield		○
Top windshield		○
For lighting	LED lights	●
	LED flickering warning lights	●
	LED rear working light	○
	LED red/blue rear working light	○
	Red/blue strip lights on rear and bilateral sides	○
	LED rotating warning light	○
Others	LED rotating and beep warning light	○
	Metric thread	●
	Solid tyre	●
	Solid tyre without travelling marking	○
	Sleeve for tilting cylinder	○
FCIS	●	

Note: "●" standard; "○" optional;

## CPD15/16/ 18/20SQ A2LiG3-M



**LIION 1.5-2 t**  
G3 series front wheel dual drive  
lithium battery truck (three wheel)



### ANHUI HELI CO., LTD.

Add / No.668, FangXing Road, Hefei, China  
 Fax / +86-551-63639966  
 Tel / +86-551-63639068(America); 63639258(Europe);  
 63639358(Asia); 63662105(Africa & Middle East)



TRADE AMERICA S.R.L.  
 +595 21 781232  
 San José 925 - Limpio - Paraguay  
[www.tradeamerica.com.py](http://www.tradeamerica.com.py)



# POWERFUL AND FLEXIBLE

-  Comfort and energy saving
-  Intelligent security
-  Stable and Reliable
-  Convenient maintenance

### APPEARANCE

The appearance is grand and the colors are beautiful; The performance is excellent.

### COMFORTABLE AND ENERGY-SAVING

The truck provides users with the best comfortable driving experience. The truck adopts advanced energy-saving technologies for a greener and more environmentally friendly environment



G3 series family design elements

Sheet metal stamping type side cover, side door



Wide view mast  
Optimized mast improves lateral stability.

Mobile phone and water cup holder offer convenient storage.

Optimized mast improves lateral stability.

The steering wheel is sensitive, lightweight, precise, and power-saving when starting and turning.

The steering wheel is optimized with height reduction  
And structure improving;  
Adjustable angle; Comfortable operation

Color screen instrument

PES third gear adjustment

P — Powerful  
E — Economical  
S — Energy-saving  
Multi performance modes satisfy the needs of various working conditions.

### FRONT WHEEL DUAL DRIVE MOTORS PROVIDE MORE POWER

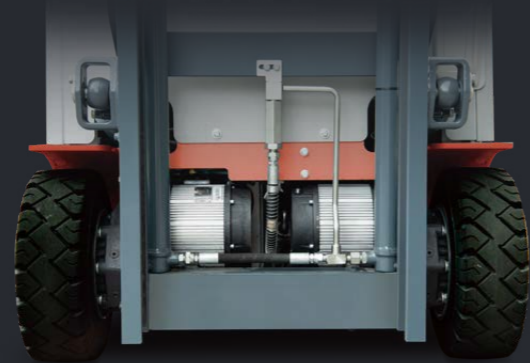

Strong performance:  
The truck is equipped with ZF dual motor drive unit.



The truck has small turning radius and good passability.



The minimum turning radius is as low as 1515mm



16km/h  
Driving speed



20%  
Maximum gradeability with load



Good bearing capacity  
at high position



0.45m/s  
Maximum lifting speed with load



0.6m/s  
Maximum lifting speed without load

### TABLE AND RELIABLE

The product is designed with the concept of stability and reliability, and has undergone multiple rigorous tests and verifications.

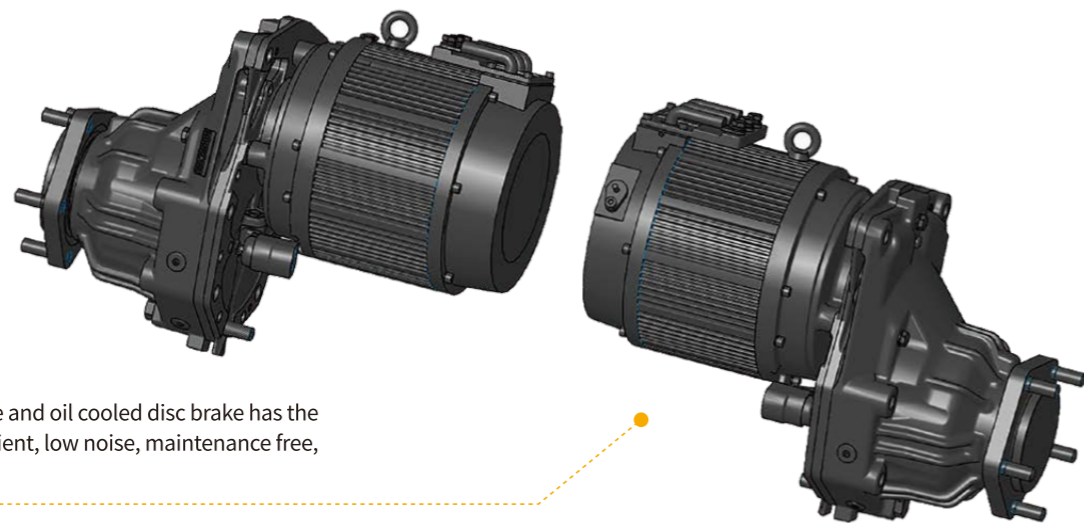

Wet type service brake and oil cooled disc brake has the characteristics of efficient, low noise, maintenance free, and reliable.



National standard fast charging port supports up to 200A fast charging



The entire truck and its components meet the latest CE & UKCA requirements.



Ratchet type hand brake is safe and reliable.

### OPERATING COSTS:

Lithium battery forklift truck **VS** Lead-acid battery forklift truck **VS** internal combustion forklift truck

The superiority of Heli lithium battery forklift is more prominent in its cost of use throughout its lifecycle. Compared with lead-acid battery truck and internal combustion truck, lithium battery truck are more cost-effective due to their maintenance free and high energy conversion rates. Compared to internal combustion trucks, lithium battery trucks have advantages such as no noise, no pollution, low vibration, and simple operation. Lithium battery trucks have the characteristics of fast charging and on-demand charging compared to lead-acid battery trucks, making them more suitable for multi shift work applications.

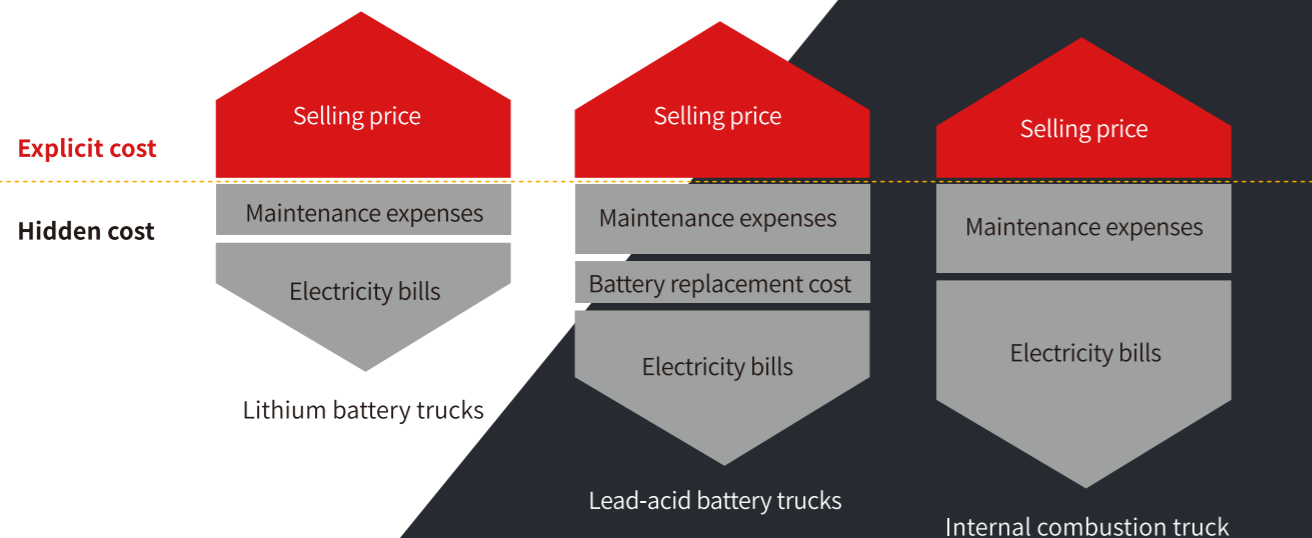

### STRICT TEST

Rain test, reliability enhancement test, vibration test, bumps test



Rain test

the truck reaches to IPX4 protection level after simulating operation under 15 min rainstorm and it meets outdoor operation requirements.



Vibration test

Conduct vibration frequency testing on the truck to optimize and improve operational comfort.



Cold storage test

The whole truck was operated alternately in a -20 °C cold storage for 6 hours, and parked in the cold storage for 12 hours. The whole truck has no faults and could operate continuously



Reliability enhancement test

The truck undergoes 800 hours of enhancement test (including climbing, rain exposure, bumpy road surfaces, etc.).

### FAST CHARGING AND ULTRA LONG BATTERY LIFE

- The truck is standard equipped with 202Ah lithium battery which has ultra long battery life.
- The battery satisfies uninterrupted operation during all day.
- The 2t truck model can be equipped with a maximum optional 404Ah lithium battery.

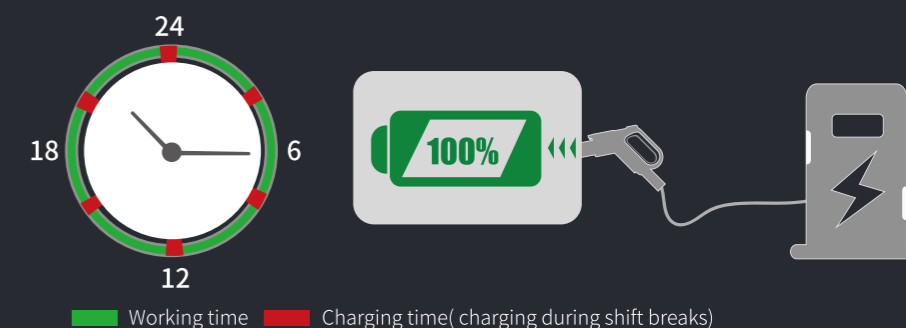

# INTELLIGENT SAFETY

The product is designed with intelligent security as its core and has multiple advanced security technologies.

- Electric brake and wet type brake offer dual protections.
- Intelligent differential speed of left and right motors
- Hydraulic pipeline anti-burst protection, forward tilt self-locking protection
- Electrical multiple protection: dual wire system, short circuit protection, overheating protection, low battery protection, sequential protection
- Parking safety reminder
- Slope sliding reminder
- Reverse handle with horn



The integrated card swiping function of the instrument meets the requirements of TSG 81.

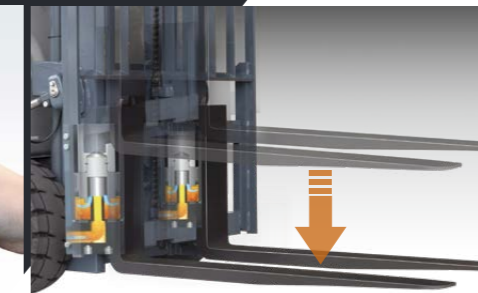

Mast lowering buffer

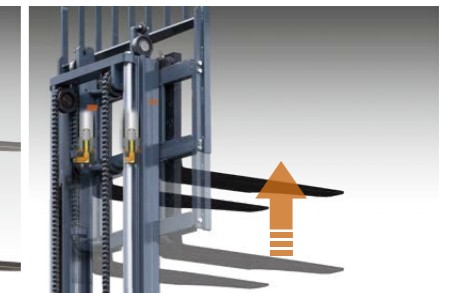

Mast lifting buffer

- Dual core controller
- Automatic deceleration for steering
- OPS

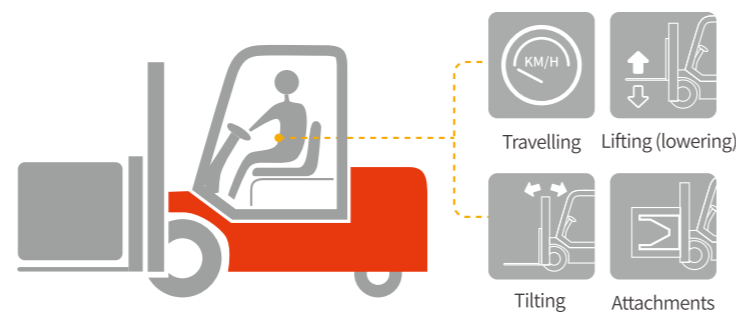
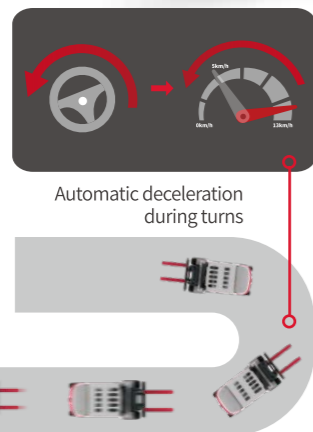

OPS (operator presence system) **Unmanned self-locking Intelligent protection**



The hydraulic oil tank is located on the left side for easy filling and checking.



Maintenance-free steering axle

## Heli Intelligent Fleet Management System (Standard Domestic Basic Edition)

Truck positioning	Statistics report
Remote diagnosis	Truck management
Remote monitoring	Identity recognition
Maintenance remind	Weighing management (optional)
Battery management	Collision management (optional)



**EASY MAINTENANCE**  
Time-saving, convenient and efficient

Manufacturer and Technical Data														
Characteristics														
1.01	Manufacturer			<b>HELI</b>										
1.02	Model			CPD15SQ	CPD16SQ	CPD18SQ	CPD20SQ							
1.03	Configuration number			A2LiG3-M	A2LiG3-M	A2LiG3-M	A2LiG3-M							
1.04	Rated capacity	Q	kg	1500	1600	1800	2000							
1.05	Load center distance	c	mm	500										
1.06	Power mode			Lithium Battery										
1.07	Driving mode			seated										
1.08	Front overhang	x	mm	367	367	367	372							
1.09	Wheelbase	y	mm	1292	1292	1292	1400							
Weight														
2.01	Total weight (with/without battery)		kg	2930/2650	3030/2750	3180/2900	3240/2960							
2.02	Axle load (laden,front/rear)		kg	3870/560	4035/595	4375/605	4600/640							
2.03	Axle load (unladen,front/rear)		kg	1365/1565	1360/1670	1365/1815	1360/1800							
Tyres														
3.01	Tyre type			Solid tyre	Solid tyre	Solid tyre	Solid tyre							
3.02	Tyre size,front			18×7-8	18×7-8	200/50-10	200/50-10							
3.03	Tyre size,rear			140/55-9										
3.04	Wheels,number front/rear(x=driven wheels)			2×/2										
3.05	Tread, front	b10	mm	920	920	930	930							
3.06	Tread, rear	b11	mm	205										
Dimensions														
4.01	Mast tilt angle (forward/backward)	α/β	°	5/7										
4.02	Height (mast lowered)	h1	mm	2000	2000	2000	2000							
4.03	Free lifting height	h2	mm	105	105	105	110							
4.04	Lifting height (standard)	h3	mm	3000										
4.05	Max. height,extended (with backrest)	h4	mm	4038										
4.06	Height of overhead guard	h6	mm	2040										
4.07	Seat height relating to SIP (to ground)	h7	mm	1042										
4.08	Towing coupling height	h10	mm	482										
4.09	Overall length (with fork)	l1	mm	2820	2835	2865	2983							
4.10	Overall length (without fork)	l2	mm	1900	1915	1945	2063							
4.11	Overall width	b1	mm	1076										
4.12	Fork size:thickness x width x length	s/e/l	mm	35×100×920	35×100×920	35×100×920	40×122×920							
4.13	Fork carriage,according to ISO2328			2A										
4.14	Distance across fork-arms, Max./Min.	b5	mm	960/200	960/200	960/200	1030/200							
4.15	Ground clearance (at mast)	m1	mm	90										
4.16	Ground clearance (center of wheelbase)	m2	mm	100										
4.17	Right angle stacking aisle width for pallet1000 x1200mm crossways	Ast	mm	3200	3220	3250	3370							
4.18	Right angle stacking aisle width for pallet800 x1200mm lengthways	Ast	mm	3330	3350	3380	3500							
4.19	Min. outside turning radius	Wa	mm	1515	1530	1560	1675							
Performance Data														
5.01	Travel speed (laden/unladen)		km/h	16/16	16/16	16/16	16/16							
5.02	Lift speed (laden/unladen)		mm/s	450/600	430/600	430/600	400/600							
5.03	Lowering speed (laden/unladen)		mm/s	470/500										
5.04	Max.drawbar pull (laden)		N	13500	13500	14000	14000							
5.05	Max.gradeability (laden/unladen)		%	20	20	20	20							
5.06	Acceleration time(10 m)(laden/unladen)		s	5.4/5	5.4/5	5.4/5	5.4/5							
Battery														
6.01	Battery voltage/Capacity		V/Ah	80/202	80/202	80/202	80/202							
6.02	Battery weight		kg	280	280	280	280							
Motor and controller														
7.01	Driving motor powering (S2-60min)		kW	5.5×2	5.5×2	5.5×2	5.5×2							
7.02	Lifting motor powering (S3-15%)		kW	16.5	16.5	16.5	16.5							
7.03	Driving motor controlling mode			MOSFET/AC										
7.04	Lifting motor controlling mode			MOSFET/AC										
Addition data														
8.01	Service brake/Parking brake			Hydraulic/mechanical										
8.02	Relief pressure		Mpa	17.5	17.5	22.5	22.5							

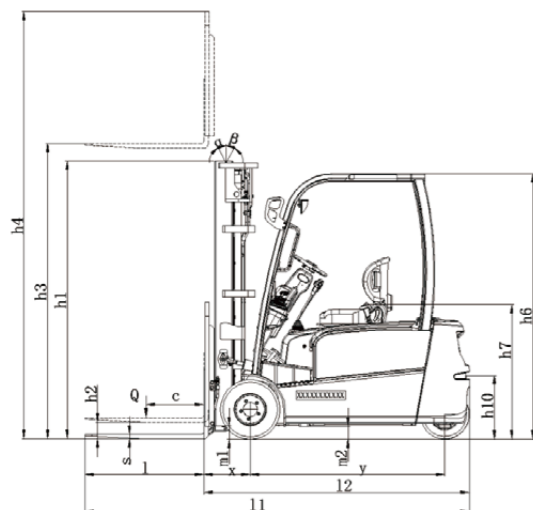

Ast: Right angle stacking aisle width  
a: Clearance 200mm

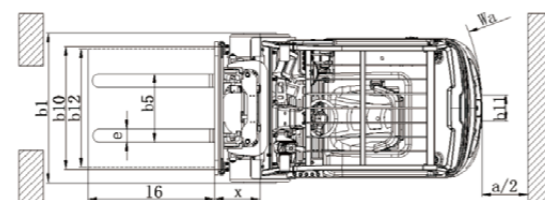

Wide View Standard Mast													
Mast Model	Max lifting height (mm)	Load capacity (lode center 500mm)(kg)				Height (mast lowered)(mm)	Free lift (with backrest) (mm)		Service weight (kg)				Mast tilting angle(°)α/β
		1.5t	1.6t	1.8t	2t		1.5-2t	1.5-1.8t	2t	1.5t	1.6t	1.8t	
M200	2000	1500	1600	1800	2000	1500	105	110	2959	3148	3255	3341	5/7
M250	2500	1500	1600	1800	2000	1750	105	110	2992	3181	3288	3374	5/7
M300	3000	1500	1600	1800	2000	2000	105	110	3025	3214	3321	3407	5/7
M330	3300	1500	1600	1800	2000	2150	105	110	3045	3234	3341	3427	5/7
M350	3500	1500	1600	1800	2000	2250	105	110	3058	3247	3354	3440	5/7
M370	3700	1500	1600	1800	2000	2350	105	110	3072	3261	3368	3454	5/7
M400	4000	1500	1600	1800	2000	2550	105	110	3123	3312	3419	3505	3/5
M425	4250	1500	1600	1750	1900	2675	105	110	3140	3329	3436	3522	3/5
M450	4500	1400	1500	1700	1850	2800	105	110	3156	3345	3452	3538	3/5
M500	5000	1300	1400	1600	1700	3050	105	110	3215	3404	3511	3597	3/3

Wide View Full Free 2-Stage Mast													
Mast Model	Max lifting height (mm)	Load capacity (lode center 500mm)(kg)				Height (mast lowered)(mm)	Free lift (with backrest) (mm)		Service weight (kg)				Mast tilting angle(°)α/β
		1.5t	1.6t	1.8t	2t		1.5-2t	1.5-1.8t	2t	1.5t	1.6t	1.8t	
ZM200	2000	1500	1600	1800	2000	1500	477	482	2953	3142	3249	3335	5/7
ZM250	2500	1500	1600	1800	2000	1750	727	732	2984	3173	3280	3366	5/7
ZM300	3000	1500	1600	1800	2000	2000	977	982	3015	3204	3311	3397	5/7
ZM330	3300	1500	1600	1800	2000	2150	1127	1132	3033	3222	3329	3415	5/7
ZM350	3500	1500	1600	1800	2000	2250	1227	1232	3045	3234	3341	3427	5/7
ZM370	3700	1500	1600	1800	2000	2350	1327	1332	3057	3246	3353	3439	5/7
ZM400	4000	1500	1600	1800	2000	2550	1527	1532	3107	3296	3403	3489	3/5

Note: the free lifting height increases by 449mm without backrest.

Wide View Full Free 3-Stage Mast													
Mast Model	Max lifting height (mm)	Load capacity (lode center 500mm)(kg)				Height (mast lowered)(mm)	Free lift (with backrest) (mm)		Service weight (kg)				Mast tilting angle(°)α/β
		1.5t	1.6t	1.8t	2t		1.5-2t	1.5-1.8t	2t	1.5t	1.6t	1.8t	
ZSM360	3600	1500	1600	1800	2000	1750	727	732	3134	3323	3430	3516	3/5
ZSM400	4000	1500	1600	1800	2000	1900	877	882	3163	3352	3459	3545	3/5
ZSM435	4350	1400	1500	1700	1900	2000	977	982	3183	3372	3479	3565	3/5
ZSM450	4500	1400	1500	1700	1850	2050	1027	1032	3193	3382	3489	3575	3/5
ZSM470	4700	1350	1450	1650	1750	2120	1097	1102	3207	3396	3503	3589	3/5
ZSM480	4800	1350	1450	1650	1750	2150	1127	1132	3213	3402	3509	3595	3/5
ZSM500	5000	1200	1300	1600	1700	2250	1227	1232	3233	3422	3529	3615	3/3
ZSM540	5400	1050	1150	1250	1400	2400	1377	1382	3262	3451	3558	3644	3/3
ZSM600	6000	800	900	1000	1100	2675	1652	1657	3347	3536	3643	3729	3/3
ZSM650	6500	700	800	900	1000	2850	1827	1832	3381	3570	3677	3763	3/3

Note: the free lifting height increases by 449mm without backrest.

Lithium battery charger									
Lithium battery brand	HEDING				ENEROC				
	202	280	404	200	228	268	302	346	400
CPD15/16/18SQ	●	○	—	○	○	○	○	—	—
CPD20SQ	●	○	○	○	○	○	○	○	○
Low temperature heating of lithium battery	●								
Charger	D80V200ALi-123 (Charging gun) /D80V200ALi-423 (Charging gun)								

Note: ● standard ○ optional — non-configurable

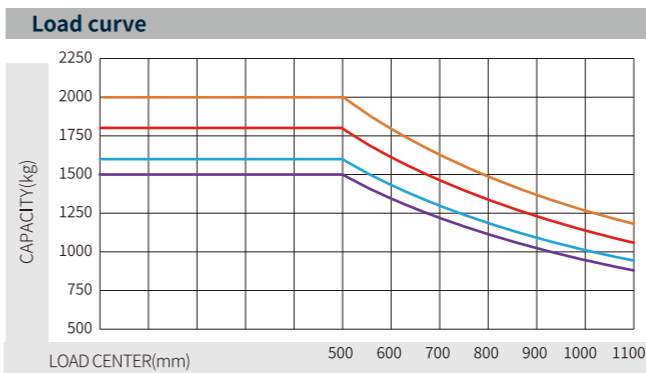

**Note:**The vertical axis stands for load capacity while the horizontal axis stands for load center which is calculated from the front surface of the forks to the gravity of the standard load. the standard load means a cubic with 1000mm edge length. When the mast is tilted forward, the worker using nonstandard forks for loading large goods, the load capacity will be reduced. The load capacity of standard mast at different load center can be known from this load chart.