

# HELI

## CQDM12/15-810 Counterbalanced Reach Stacker

### Load Curve

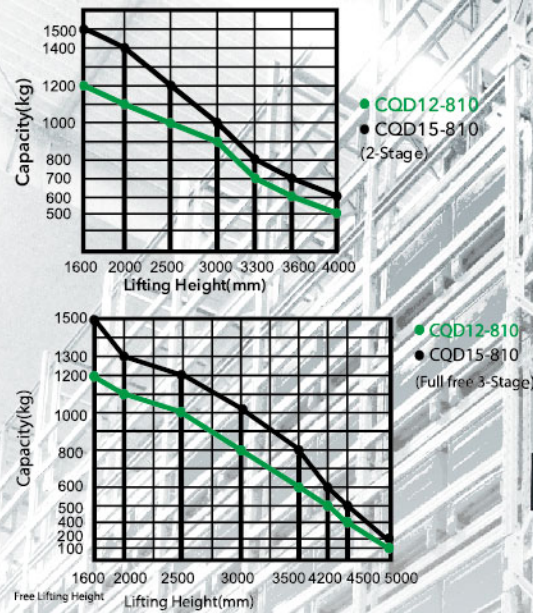

### Configuration and performance

- Fork tilt, double oil cylinder more smoothly.
- Electro-hydraulic integrated control, multi-function handle.
- Electronic power steering system, light and low noise.
- Two-way magnetic valve, three drop speed mode.
- AC Driving system, No carbon brush, maintenance free.
- Electromagnetic, regenerative braking system.
- Automatic lifting limit, proximity switch, long life.

### Safety

- Curve automatic deceleration devices, more safe.
- Vehicle decelerates automatically at higher position.
- Stepless speed control system, safe and quiet.
- Controller with Multiple automatic protection.
- Emergency reversing device/Emergency brake switch.
- High position automatic reduction device.

### Option

- Lithium battery



AC | EPS

Down mode at 3 speeds

Standard fork tilt device

Type	Lift height (mm)	Mast type	Outside width between forks (mm)	Inside width between forks (mm)
CQDM12/15-810	1400/2000/2500/3000/3300/3600/4000	Standard 2-STAGE	200-755	0-555
CQDM12/15-810	2500/3700/3900/4200/4500/5000	FULL FREE 3-STAGE		

## CQDM12/15-810

Feature		CQDM12/15	CQDM12/15
Model		810	810
Configuration No.		Reach	Reach
Type		Standard 2-Stage	Full free 3-Stage
Mast type		1200/1500	1200/1500
Load capacity	kg	500	500
Load center	mm	1332	1332
Wheel base	mm	Stand On	Stand On
Operating type			
<b>Wheels</b>			
Wheels type		PU	PU
Wheel quantity Driving wheel/ Balance wheel/Bearing wheel		1/0/2	1/0/2
<b>Dimension</b>			
Reach distance	mm	0-425	0-425
Standard lift height	mm	1400/2000/2500/3000/3300/3600/4000	2500/3700/3900/4200/4500/5000
Max. extend height	mm	2280/2880/3380/3880/4180/4480/4880	3405/4605/4805/5105/5405/5905
Mast lowered height	mm	1490/1790/2040/2290/2440/2590/2790	1432/1870/1940/2040/2140/2359
Lowered fork height	mm	55	55
Fork size(length/width/thickness)	mm	1070/100/40	1070/100/40
Overall length	mm	2440/2896	2440/2896
Overall width	mm	1083	1083
Outside width between forks	mm	200-755	200-755
Tilt of fork(F/B)	mm	3/5	3/5
Min. Turning radius	mm	1596/2040	1596/2040
Min. Aisle width for pallets 800×1200	mm	2620/3050	2620/3050
Min. Aisle width for pallets 1000×1200	mm	2645/3075	2645/3075
Min. ground clearance	mm	60	60
<b>Performance</b>			
Travel speed, laden/unladen	km/h	5/5.5	5/5.5
Lift speed, laden/unladen	mm/s	130/180	130/180
Lowering speed, laden/unladen	mm/s	100/180	100/180
Gradeability, laden/unladen	%	3/5	3/5
<b>Electrical configuration</b>			
Drive motor/Lift motor/Steering motor	KW	AC1.5/DC3.0/DC0.15	AC1.5/DC3.0/DC0.15
Brake		Electromagnetic/Regenerative	Electromagnetic/Regenerative
<b>Weight</b>		Lead-acid battery	Lithium battery (Optional)
Battery voltage	V	24	24
Battery capacity	Ah	280	200
Controller		ZAPI	ZAPI
Battery weight	kg	235	105
Service weight with battery	kg	2185	2069
		Lead-acid battery	Lithium battery (Optional)
		24	24
		280	200
		ZAPI	ZAPI
		235	105
		2205	2220

\* Details of specifications and equipment are based on information available at time of printing and may change without notice.

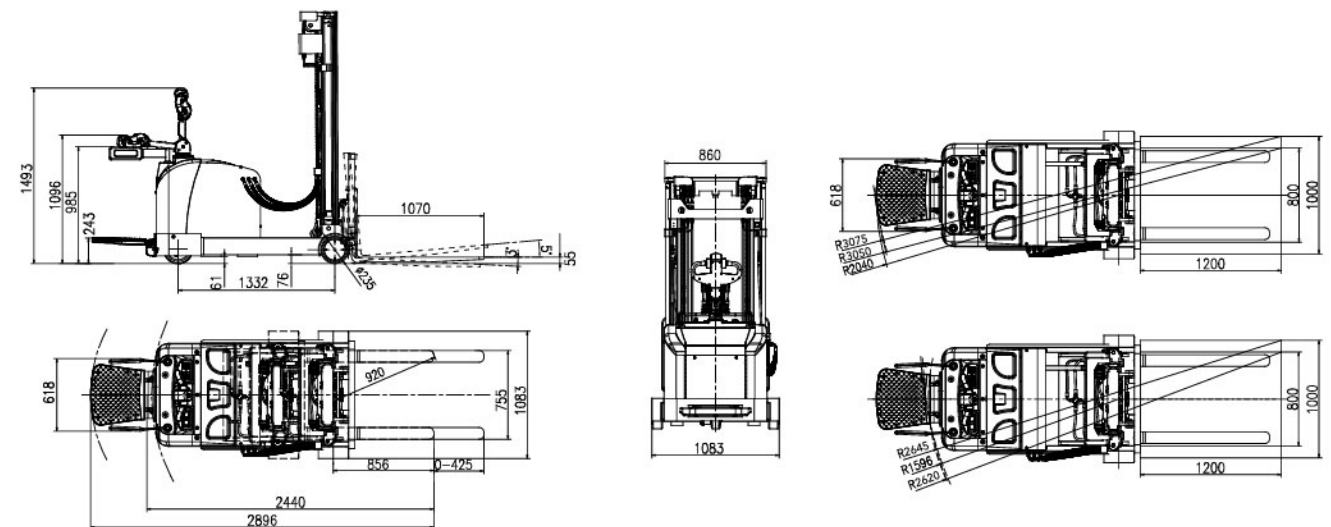

### ANHUI HELI CO., LTD.

ADD: NO.668 Fangxing Street, Economical Development Zone, Hefei, P.R. China  
 TEL: (86 551)63639068 (America) 63639258 (Europe) 63639358 (Asia)  
 63662105 (Africa & Middle East) 63639530 (Key Accounts division)  
 63662105 (Wheel loader)  
 FAX: (86 551)63639966  
 WEBSITE: <http://www.heliforklift.net>  
 Email: [heli@helichina.net](mailto:heli@helichina.net)



TRADE AMERICA S.R.L.  
 +595 21 781232  
 San José 925 - Limpio - Paraguay  
[www.tradeamerica.com.py](http://www.tradeamerica.com.py)